



Design and Fabrication of Autonomous Wall Printing Machine

Alan G Lal, B Mohan Reddy and Mudabbir Ahmed Khan

EasyChair preprints are intended for rapid dissemination of research results and are integrated with the rest of EasyChair.

May 29, 2023

PES UNIVERSITY

(Established under Karnataka Act No.16 of 2013)

UE19ME380B- VII Semester Capstone Project Work Phase – II

Dissertation on

Design and Fabrication of Autonomous Wall Printing Machine

Submitted by

**Alan G Lal (PES2UG19ME003) Mohan
Reddy B (PES2UG19ME024) Mudabbir
Ahmed Khan (PES2UG19ME026)**

Aug-Dec 2022

under the guidance of

Guide

Dr. S.V.Satish

Professor and Chairperson

Department of Mechanical Engineering

PES University, Electronic City Campus

Bengaluru- 560100

PES UNIVERSITY

(Established under Karnataka Act No.16 of 2013)

**DEPARTMENT OF MECHANICAL ENGINEERING
PROGRAM B. TECH – MECHANICAL ENGINEERING**

CERTIFICATE

This is to certify that the Dissertation entitled

“Design and Fabrication of Autonomous Wall Printing Machine”

is a bonafide work carried out by

Alan G Lal (PES2UG19ME003)

Mohan Reddy B (PES2UG19ME024)

Mudabbir Ahmed Khan (PES2UG19ME026)

In fulfilment for the completion of course work in the Program of Study **B.Tech in Mechanical Engineering** under rules and regulations of **PES University**, Bengaluru during the period Aug-Dec 2022. It is certified that all corrections/suggestions indicated for internal assessment have been incorporated in the report. The dissertation has been approved as it satisfies the 7th semester academic requirements in respect of project work.

Project Guide

Department Chairperson

Signature

Signature with Date and Seal

Signature of Examiners during Viva-Voce (ESA)

| Name | Affiliation | Signature with Date |
|------|-------------|---------------------|
| | | |
| | | |
| | | |

PES UNIVERSITY

(Established under Karnataka Act No. 16 of 2013)

DECLARATION

We, **Alan G Lal, Mohan Reddy B, Mudabbir Ahmed Khan**, hereby declare that the dissertation entitled, *Design and Fabrication of Autonomous Wall Printing Machine*, is an original work done by us under the guidance of **Guide Dr. S.V. Satish**, Professor and Chairperson, Mechanical Engineering, and is being submitted in fulfilment of the requirements for completion of 7th Semester course work in the Program of Study **B. Tech in Mechanical Engineering**.

Place: Bengaluru Date:

| Name and Signature of Candidates | | |
|---|---------------|------------------|
| Name | SRN | Signature |
| Alan G Lal | PES2UG19ME003 | |
| Mohan Reddy B | PES2UG19ME024 | |
| Mudabbir Ahmed Khan | PES2UG19ME026 | |

PES UNIVERSITY

(Established under Karnataka Act No. 16 of 2013)

ACKNOWLEDGEMENT

We have taken a lot of effort and put in tons of hard work to complete this project. However, completing this project would not have been possible without the support and guidance of a lot of individuals for whom we would like to express our gratitude, and extend our sincere thanks to all of them.

We would like to thank our **Pro chancellor, Dr. D Jawahar**, and our **Vice chancellor, Dr. J Surya Prasad**, for providing us with the excellent infrastructure and an unending encouragement which made this project a success.

We express our sincere gratitude to our project guide **Dr. S V Satish, Chairperson of the Department of Mechanical Engineering**, for his valued cooperation in completion of this project and report and for his keen eye for details and valuable insights.

We would like to place on record our deep appreciation and gratitude towards our project coordinator **Mr. Vinay P, Assistant Professor, Department of Mechanical Engineering** for always being there to help us with his valuable guidance and encouragement.

Finally, we would like to extend our sincere gratitude to the **teaching and non-teaching staff of the Department of Mechanical Engineering**, for extending their cooperation and being a constant source of inspiration behind this report.

TABLE OF CONTENTS

| Sl.No | Content | Page. No |
|--------------|--|-----------------|
| 1. | Abstract | 9 |
| 2. | Introduction | 10-12 |
| 3. | Literature Review | 13 |
| 4. | Research Gap | 14 |
| 5. | Objective | 15 |
| 6. | Methodology | 16 |
| 7 | Project work details | 17 |
| 8. | Component details of electronics | 17-25 |
| 9. | Component details of Hardware and CAD models | 26-49 |
| 10. | Numerical scheme | 50 |

| | | |
|-----|--------------------------------------|-------|
| 11. | Flow chart | 51 |
| 12. | Experimental setup and calibration | 52-53 |
| 13. | Investigation and Reductions | 54-56 |
| 14. | Bill of Materials | 57-61 |
| 15. | Results and Discussions | 62 |
| 16. | Conclusion and Scope for Future Work | 63 |
| 17. | References | 64 |

TABLE OF FIGURES

| Figure Number | Figure Name | Page. No |
|----------------------|-----------------------------|-----------------|
| 5.1. | Screen width vs distance | 16 |
| 6.1. | Print Head | 17 |
| 6.2. | Decoder Board | 18 |
| 6.3. | Stepper Motor | 19 |
| 6.4. | Stepper motor driver | 20 |
| 6.5. | Stepper motor driver HBS86H | 20 |
| 6.6. | UV light | 21 |
| 6.7. | Motherboard | 21 |
| 6.8. | Hard disk | 22 |
| 6.9. | Monitor | 22 |

| | | |
|-------|---------------------------------|----|
| 6.10. | SMPS | 23 |
| 6.11. | Power button | 23 |
| 6.12. | Cooling fan | 24 |
| 6.13. | Keyboard and mouse | 24 |
| 6.14. | Positioner | 25 |
| 7.1. | Front/top view of fixed beams | 26 |
| 7.2. | Front/top view of folding beams | 27 |
| 7.3. | Side view of folding beams | 27 |
| 7.4. | Side view of hinges | 28 |

| | | |
|-------|-------------------------------------|----|
| 7.5. | Top View of hinges | 28 |
| 7.6. | Side/front view of support bars | 29 |
| 7.7. | Top view of pulley | 29 |
| 7.8. | Side view of pulley for small motor | 30 |
| 7.9. | Top view of pulley for small motor | 30 |
| 7.10. | Front view of support bars | 31 |
| 7.11. | Side view of support bars | 31 |
| 7.12. | Top view of support bars | 31 |
| 7.13. | Front view of ink tank | 32 |

| | | |
|-------|---------------------------------|----|
| 7.14. | Side view of ink tank | 32 |
| 7.15. | Top view of ink tank | 32 |
| 7.16. | Top view of base | 33 |
| 7.17. | Side view of wheel | 34 |
| 7.18. | Top view of wheel | 34 |
| 7.19. | Front view of support structure | 35 |
| 7.20. | Side view of support structure | 35 |
| 7.21. | Top view of support structure | 35 |
| 7.22. | Side view of rubber stopper | 36 |

| | | |
|-------|-------------------------------|----|
| 7.23. | Top view of rubber stopper | 36 |
| 7.24. | Front view of support bar | 37 |
| 7.25. | Side view of support bar | 37 |
| 7.26. | Top view of support bar | 37 |
| 7.27. | Front view of folding support | 38 |
| 7.28. | Top view of folding support | 38 |
| 7.29. | Side view of bigger pulley | 40 |
| 7.30. | Top view of bigger pulley | 40 |
| 7.31. | Front view of ball bearing | 41 |
| 7.32. | Side view of ball bearing | 41 |

| | | |
|-------|----------------------------|----|
| 7.33. | Side view of pulley | 42 |
| 7.34. | Top view of pulley | 42 |
| 7.35. | Front view of axle support | 43 |

| | | |
|-------|-----------------------------|----|
| 7.36. | Side view of axle support | 43 |
| 7.37. | Top view of axle support | 43 |
| 7.38. | Front view of axle | 44 |
| 7.39. | Side view of axle | 44 |
| 7.40. | Front view of stepper motor | 45 |
| 7.41. | Side view of stepper motor | 45 |

| | | |
|-------|-----------------------------|----|
| 7.42. | Top view of stepper support | 45 |
| 7.43. | Front view of pulley travel | 46 |
| 7.44. | Top view of pulley travel | 46 |
| 7.45. | Front view of head plate | 47 |
| 7.46. | Side view of head plate | 47 |
| 7.47. | Top view of head plate | 47 |
| 7.48. | Front view of roller mount | 48 |
| 7.49. | Side view of roller mount | 48 |
| 7.50. | Front view of rollers | 49 |
| 7.51. | Top view of rollers | 49 |

| | | |
|-------|--------------------|----|
| 10.1. | Head side | 52 |
| 10.2. | Decoder board | 52 |
| 10.3. | Flat cables | 52 |
| 10.4. | Head nozzles | 53 |
| 10.5. | Fan | 53 |
| 10.6. | Stepper driver | 53 |
| 11.1. | Ink tank 4 chamber | 54 |
| 11.2. | Ink tank 6 chamber | 54 |
| 11.3. | Nozzle | 55 |
| 11.4. | Image | 55 |

ABSTRACT

The primary aim of our project is to design, develop and implement Autonomous Wall Printing Machine which will help to achieve low-cost printing equipment as compared to the conventional methods which are existing today. Wall paintings have been for variety of reasons in our surroundings like signage boards, wall murals, directional signs, or for aesthetic reasons. All of this requires skilled operator who need to work for longer hours to achieve good finishes. The conventional wall painting which is done by hand would cost anywhere around 55 to ₹75 per square feet which is inclusive of labor charges. This machine would finish the same job at a 35-50% cut in the market rates. The minimum amount of time required for paintings done by hand to dry in a suitable daily environment is around 4 to 5 hours, certain times the conditions may not be favorable for allowing the entire painting to dry. the chemicals which are used in paints produce a strong odor and they're very hazardous when inhaled by a human. The people who do this job are at the higher risk of developing lung infections. In this machine the printed area will dry within 5 to 6 seconds with the help of UV curing. The maximum height which our printer can reach is 8 feet, and the maximum width Is not limited. The printing machine is capable of auto adjusting images according to the aspect ratio, or also do standard size prints such as 4 feet by 3 feet. The different aspect ratios to which the machine is set is 1:1 which produces a square print, 7:5, 16: 9. In addition to this the machine would also allow the user to print at different speeds which includes slow, normal, fast. the total time which is required for the setup of the machine is around 10 minutes from the time it starts printing. The slowest speed would print a 1.8 inch by 1.8-inch picture at normal quality in 22 minutes and 31 seconds. Normal speed is 25% faster than the slowest speed available in the setting and the fastest speed available is 25% faster than the normal speed available in the setting. In addition to all of this he could offer the opportunity to reduce and eliminate human exposure to hazardous environment which is the major safety concern today. These factors motivate the development of this project, and this report will be containing the detailed aspects of the same.

CHAPTER 1

INTRODUCTION

Building and construction is one of the significant industries around the globe. In this fastmoving industrial development, this industry is growing at a rapid pace. Another industry which is more on the other spectrum and comes under technology electronics is the printing industry. The place where commodity industry meets the electronics is in wall printing. Walls are printed for indicating many things and this task would require a skilled painter who has ideas on colour match-mix, dimensioning. this entire process of printing a wall would turn out to be expensive considering the number of walls which needed to be painted in the entire building of an organization. the conventional process is also very time consuming and inaccurate when it comes to dimensioning, colors, because this would entirely depend on the experience of the painter. The machine which is demonstrated here uses the technology of dimensioning and colour mixing backed by a powerful software which can give control on various parameters like resolution, colour bit depth and speed. The main parts of the machine which would be bearing loads of various components are fabricated using aerospace grade aluminum. 70% of the machine uses aerospace grade aluminum onto which electronics are mounted. Other materials such as steel, would pose a challenge to the weight of the entire machine, this would require us to also upgrade the motors which are used for the movement. Aerospace grade aluminum is one of the strongest alloys in the market and it has a very low mass. This alloy is perfect for crafts that need to stand up to tough conditions and the same material is also used in aircrafts We are currently using grade 7068 of aluminum. Considering that this machine uses ultraviolet rays for curing the printed area using other materials such as steel would affect the life of the machine, as steel is not resistant to UV damage. It uses powerful stepper motors which are connected using tooth belts which coordinate together to produce the final picture. motors which are used are selected keeping in mind the amount of tension, stress, and the working condition of the machine, are two specifications above the normal which would be required for the normal movement of the machine. This make sure that reliability is not a concern in the long run. It has a longer life as expected to other printers due to the good selection of materials and high-grade build quality. It is highly efficient in terms of power consumed and ink recharging. We have also made sure it is very easy and cheap to maintain. This machine can also serve as a business for printing on commercial buildings which need to have images, signs, which are stationary and can't be moved for a comparatively low cost

rather than getting them painted by an artist or printed on a material and then stuck. The machine uses software which named Print Dream to execute the printing operations. This software is used in industrial printing and is only compatible with industrial print heads and decoders. In this software the user can set start position, passes, directions of prints, and various other parameters such as return to home position. From print head perspective, the software can check for chamber blocking, insufficient ink pressure, low ink levels, and warn the user if the print can be completed or not. There is operation known as flash which will show if the constituent chambers of the head are in working condition. Once this command is given 4 lines consisting cyan, magenta, yellow and black can be seen on the wall in a horizontal pattern. If this operation is unsuccessful, user needs to check the ink levels, and ensure there is sufficient pressure from the ink tank by noting the pressure release nozzles. These pressure nozzles are present on the ink tank and are tiny holes in each chamber of the tank. The nozzles when open will allow the atmospheric air to come into the chambers of the ink tank, this will make sure that there is more pressure inside the chambers than at the print head. Due to the pressure difference the ink flow is smooth and laminar. These pressure nozzles need to be open mandatorily when giving a print command for the smoothest and hassle-free operation. Not ensuring this would make the head malfunction and induce a back flow from the head due to negative pressure when printing, and the head chambers would be blocked. Assisting all this the print head also would be manually pressurized using a suction tool every time the machine is moved for printing from different destinations. This would make sure that there is no load at head end at the start of the prints. To simplify things further the construction of the Wall printing machine consists of 3 parts which we have divided into:

1. Base Setup

1.1.Motors

Department of Mechanical Engineering, PES University

- 1.2.Print Head
 - 1.3.Decoding board
 - 1.4.Ink tank and supply
 - 1.5.Wheels on four corners
 - 1.6.Pulley
 - 1.7.Centre Axle
 - 1.8.UV Curing light
-
2. Vertical Aluminium Extrusions
 - 2.1. 6 wheels for head fit into V slot of Aluminium rods
 - 2.2.Hinges
 - 2.3.Rubber stoppers
 - 2.4.Pulley
 - 2.5.Inclination supports
-
3. Wooden Box
 - 3.1.Motherboard consisting of RAM and processor
 - 3.2.Hard disk
 - 3.3.Stepper motor drivers
 - 3.4. UV light supply
 - 2.5.SMPS
 - 3.6. On/off for monitor and CPU
 - 3.7.Monitor
 - 3.8.Mouse and keyboard

CHAPTER 2

LITERATURE REVIEW

2.1.NCMPC- 2019 Proceedings: This paper was done by 4 final year students in Karnataka, India. In this the authors designed and fabricated an automatic wall painting robot which could span floors for the requirements. They used a spray gun and chain assembly for movement and employed the use of IR sensors to self-scan for any obstructions. The drawback here with this is there is only a singleton colour scheme achievable as there is no technology to mix colours and job is only for a given cycle. If colours need to be changed in between the machine is incapable of it and must be loaded with the specific colour again after flushing.

2.2.Berardo Naticchia: In this paper, the author uses a mechanical arm which is automated using software and scans for quality checks using a scanner. It also uses a system to convert the normalized coordinates of the liquid colours to be reproduced into movement of speed of the robot end tool and there is also a valve which opens closes for mixing colours. There is a mixing board as well which is coded for mixing on operation. The research gap found here was the board was not capable of mixing many colours together and it is a single valve and nozzle system which is used for the job; hence accuracy and finishes are not good. There are also no movement sensors to detect obstacle in trajectory.

2.3. ACP Sheets for Building Exteriors by ARECA: In this paper, author describes the use of ACP (Aluminium Composite panel) for the use of building facades. Instead of using conventional paint on the exteriors, ACP which is an alloy of aluminium and polyurethane is used. The main reason for this is due to its service life, low maintenance cost, and structural rigidity which it offers. It is also available at an attractive price when compared to the cost of the painting the full wall. So, the paint which would depict the logo, or the signage would be replaced by this print which would be directly on to the ACP sheet. The printing would need to be done according to split graphics where one sheet would hold certain number of graphics when printed together and assembled with the print pattern would show the entire sign, or logo viewed from a greater distance.

CHAPTER

3

RESEARCH GAP

Major methodology in the wall painting machine which was demonstrated in the review papers contained single colour components, the user needs to change the colour component if multi colour picture/painting needs to be produced. The machines used a compressor which would force in air through a nozzle and a container and would produce images. There is no concept where there is software implemented for the mixing of colour and the final component which is going to give colour output is non electronic in such cases. Here a head is used to give final output, there is a minimum gap which is maintained between the printing surface and the head and is a contactless process. Constituent colours used in this machine are Cyan, Magenta, Yellow and black which is like any other inkjet technology used today. Other print heads used have a rack arrangement where there is a rail which is the size of the input paper, and the head will displace over this rail to produce images. The entire printing process in this type of method is supported by gravity and requires no special pressurizing of ink, in this machine there is a requirement of pressurizing the ink since it is a vertical arrangement. Gravity acts perpendicular to the axis of printing and hence this machine has a UV curing system for drying out the ink on the printing medium.

CHAPTER

4

OBJECTIVE

- To create a machine which would print in a vertical arrangement on a surface without making contact to the printing medium.
- To make sure that there is a medium to dry the printed surface quickly and without changing the properties of the colour.
- The printer is should auto adjust the size according to the resolution of the print given. Clarity should be maintained regardless of the size of print given.
- The boundaries of the printer must be well defined so that images are clear when viewed from a larger distance.

CHAPTER

5

METHODOLOGY AND MATHEMATICS

Any picture or object would only be clear to the point of view if the aspect ratio and the distance of viewing is in forms of arithmetic progression. The viewing distance is proportional to the print width which would be done on the wall with an angle of 36 degrees. To put simplify things, we have shown in a pictorial representation which is like viewing distance of televisions.

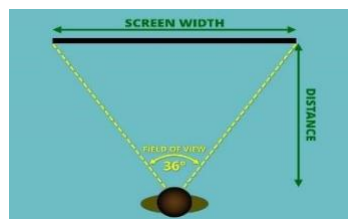

Figure Number 5.1. Screen width vs Distance

The resolution which needs to be printed keeping dpi into consideration also boils down to the viewing distance. So, the most important thing in our project is the aspect ratio which we will be printing and not the resolution. A high-resolution picture would show a lot of noise when viewed from a greater distance. We have set the resolutions according to the surrounding and viewing distance which it would be printing for. Hence keeping all this into mind there are corrections for the maximum height reachable by the head. Maximum height for good resolution viewing: 1350 mm from base

Above this level the print head will stop due to lack of extrusion support

Maximum height of print after 1350 mm distance is set: 20 inches

If picture height is given more than this print head stops due to lack of extrusion support.

Maximum width according to height set:

This is inbuilt in the software which we are using to give print command. Typically:

Viewing Distance/2 = Diagonal size with 45-degree angle in inches.

This is the common formula used even by TV manufacturers.

CHAPTER

Any images above the line of sight of 6ft are termed to have a lot of noise and grain disturbance, hence printer can print total of 6.5 ft as threshold.

6

PROJECT WORK DETAILS

6.1. COMPONENT DETAILS OF ELECTRONICS

6.1.1. EPSON 4720 Print Head

First locked (print heads come in locking of colour bit which ranges from 1,2 and so on. The first lock indicated the bit variations the print head can produce

Width: 60mm

Height: 50mm

Number of Nozzles: 4 for CMYK colours.

Compatibility: Windows XP/Vista/2000/7.

Place of Assembly: Front mounted with a boundary backed aluminium plate for support and sturdiness. 6 Philips screws used for securing it in place. 2 in the side. 4 on the frontal.

Origin: EPSON, China.



Figure Number 6.1. Head

CHAPTER

6.1.2. Decoder Board

Width: 45mm

Height: 50mm

Version number: 1.2.4720

Compatibility: used for EPSON 4720 head dx7 first/second unlocked.

14 pin slots: 4

16 pin slots: 4

4 LED indicators in amber colour for working indication.

Place of Assembly: Behind the tubing in centre axis of the head assembly. Mounted with 3 Philips screws on top left/right and bottom right.

Origin: EPSON, China.



Figure Number 6.2. Decoder Board

6.1.3. Stepper Motors

Profile: Cylindrical Profile

Quantity used: 3

1st motor used for movement of wheels and is connected to the axle using a tension belt.

1st motor specifications:

Step angle: +/-5%

Resistance accuracy: +/- 10%

Inductance accuracy: +/-20%

Temperature rise: 80 degrees

Dielectric strength: 500VAC

Radial Runout: 0.06 max

Phases: 2

Step Count: 1.8 degrees per step

Max torque: 8.5Nm each at full supply

Voltage: 24 V peak

Manufacturing material: Fibre shell for protection and cylindrical output. Can be connected to gear tooth or pulley.

2nd motor specifications: connected for head vertical axis head movement

Step angle: +/-5%

Resistance accuracy: +/- 10%

Inductance accuracy: +/-20%

Temperature rise: 80 degrees

Dielectric strength: 500VAC

Radial Runout: 0.06 max

Phases: 2

Step Count: 1.8 degrees per step

Max torque: 18.5Nm each at full supply with losses

Voltage: 24 V peak

Manufacturing material: Fibre shell for protection and cylindrical output. Can be connected to gear tooth or pulley.



Figure Number 6.3. Stepper motor

6.1.4. Stepper Motor Driver

6.1.4.1.DMA860H stepper

Stepping Voltage: 24V to 60V peak

Current: 7.2 A

Supply- 18-80VAC

Resistance: 500Mohm



Figure Number 6.4. Stepper Motor Driver

6.1.4.2.HBS86H Hybrid Servo Drive

Channels: 16

VAC: 18- 70 V

VDC: 24- 100V

The 860H stepper is used to drive the 4 robo wheels in the base of the assembly.

The servo drive is used only for vertical head movement.

Material: Plastic

Place of Assembly: Inside wooden box.

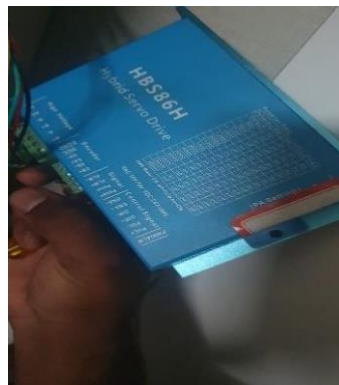

Figure Number 6.5. Stepper Motor Driver HBS86H

6.1.5. UV Curing light Input

Voltage: 24 V

Current: 3.4 A

Intensity variable switch

Place of Assembly: On top of head.



Figure Number 6.6. UV light

6.1.6. Motherboard

Windows 7 AMD motherboard 8 core CPU, 250GB Hard disk, USB 2.0 interfaces.

Supply: SMPS normal output voltage.

Output slots: VGA, sound

Input: Mouse via USB, power supply, ethernet port.

Place of assembly: Inside wooden box.



Figure Number 6.7. Motherboard

6.1.7. Hard disk

250GB American Megatrends Hard disk.

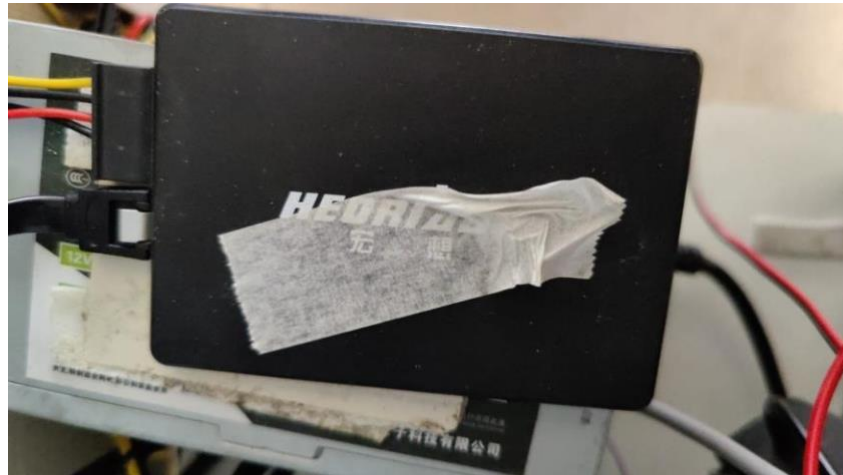

Figure Number 6.8. Hard Disk

6.1.8. Monitor

Resolution: 1280 by 720

Output: via VGA cable

Input: Circular connector

Place of Assembly: On top of wooden box

Frequency: 60 Hz

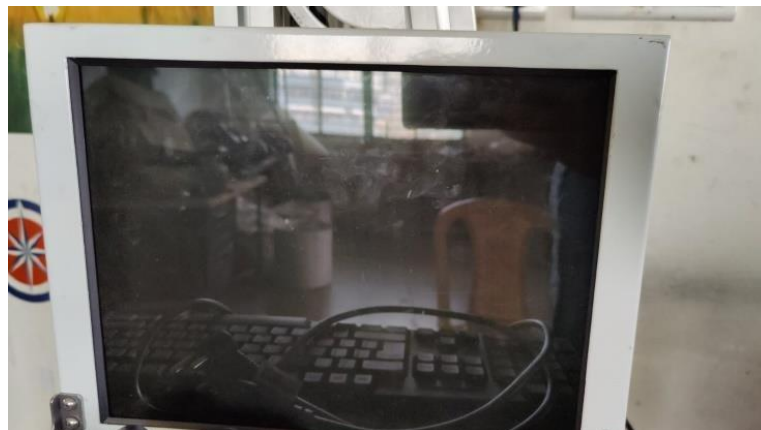

Figure Number 6.9. Monitor

6.1.9. SMPS

Supply: 450W supply for motherboard and steppers

Origin: Zebronics, India

Input: 3 pins to 3 phase plug connectors

Output: DSATA 20+4 pin

Place of Assembly: Inside the wooden box



Figure Number 6.10. SMPS

6.1.10. Power buttons

2 circular designed buttons along with backlight

Quantity: 2

Place of Assembly: Side of wooden box



Figure Number 6.11. Power buttons

6.1.11. Cooling fan Material:

Plastic

Origin: Snowfan

Place of Assembly: Inside wooden box



Figure Number 6.12. Cooling Fan

6.1.12. Keyboard and Mouse Frequency:

2.4 GHz

Output: USB 2.0

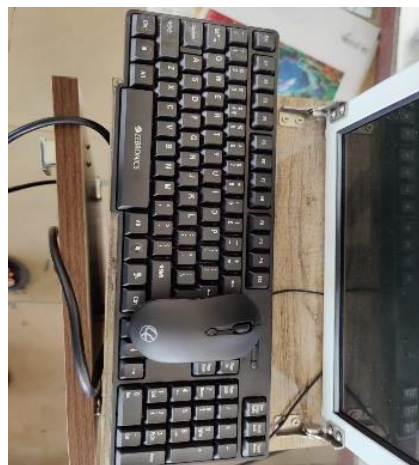

Figure Number 6.13. Keyboard and Mouse

6.1.13. Laser Positioner

Material: Plastic

XY plane positioner projects lines for calculations.

Place of Assembly: On top of decoder board.

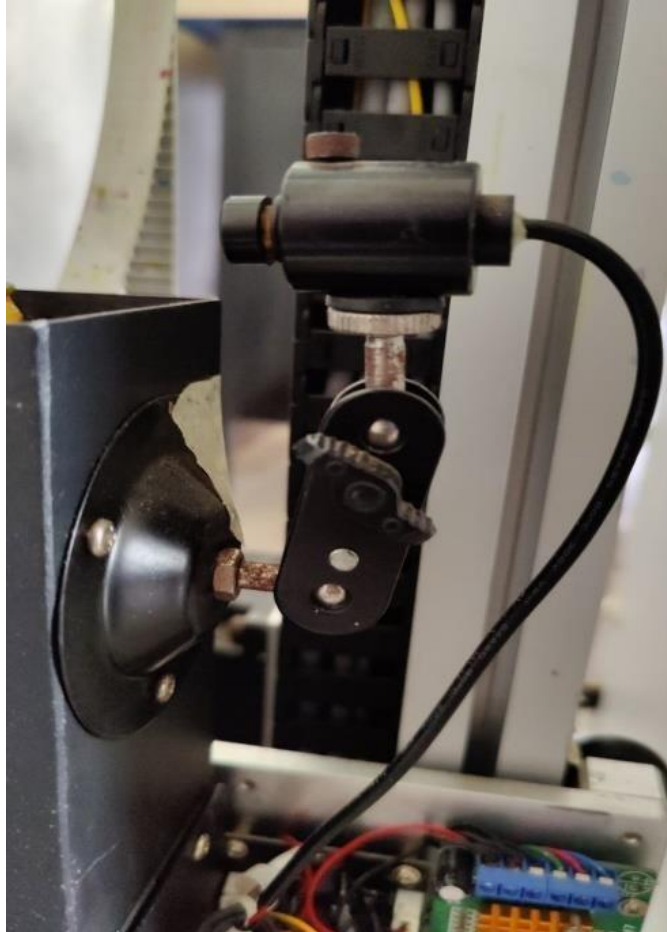

Figure Number 6.14. Laser Positioner

CHAPTER 7

COMPONENT DETAILS OF HARDWARE AND CAD MODELLING

7.1. Aluminium Extrusions

7.1.1. Extrusion (fixed to the base)

Length: 1500 mm

Width: 40 mm

Height: 40mm

Weight: 2250grams each

Quantity: 2

Assumptions made:

Weight of head along with electronics is assumed to be 4.5kgs and the force required to lift this is equal to the mass times acceleration which is equal 44.145N.

Head assembly mounted to left side rod. Another identical rod is used to counterbalance the forces of bending and inertia of self-weight during movement.

Force needs to be divided into 2 rods since one is used as counterbalance.

Hence total force per rod is 22N approx.

Distance between 2 rods: 220mm

Total volume of the rods: 700000 mm³

Density: 2710 kg/m³

Mass: 1.897 kgs

Components attached: Support bars and rubber stopper

Material: Aerospace grade aluminium

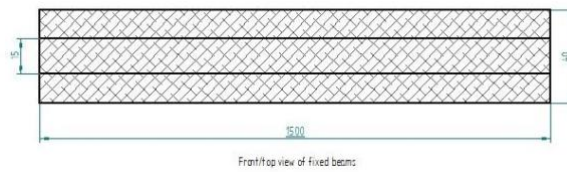

Figure Number 7.1.: Front/top view of fixed beams

7.1.2. Extrusion (hinged to first extrusion using 300mm plate)

Length: 1010 mm

Width: 40 mm

Height: 40 mm

Weight: 1750 grams each

Quantity: 2

Head assembly mounted to left side rod. Another identical rod is used to counterbalance the forces of bending and inertia of self-weight during movement. 440 mm plate with centre pulley is used for belt tensioning. Rubber stopper to prevent height malfunction and to stop head from coming out, acts as a safety feature.

Accompanied by U shape plates with 70mm circumference for letting of tension when this part of the assembly is bent using the hinges.

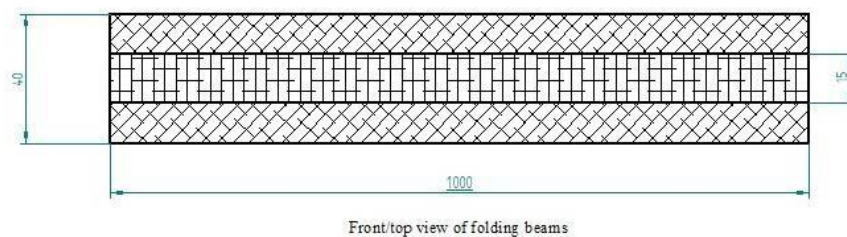

Figure Number.7.2: Front View and top view of Folding beams

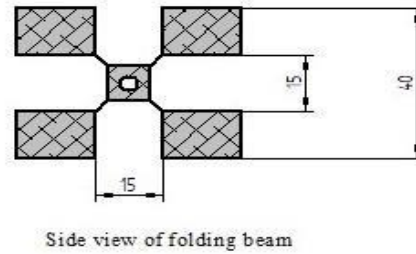

Figure Number.7.3: Side view of Folding Beam

7.1.3. Hinges Angle: 180

degrees

Quantity: 2

Material: Aluminium

Tightened using Allen bolts of size 6.

Figure Number: Front view of hinges

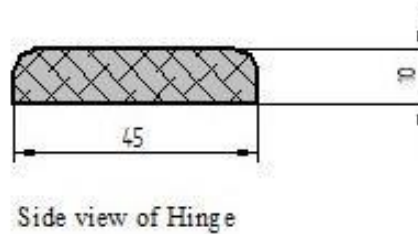

Figure Number.7.4: Side view of Hinges

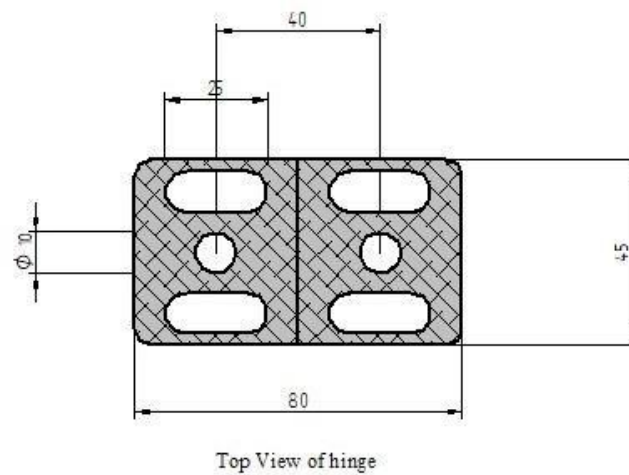

Figure Number.7.5: Top View of Hinges

7.1.4. Pulleys

1st pulley (fixed to the top part of assembly)

Diameter: 40 mm

Number of teeth: 22

Material: Aluminium fibre

Fixed and tightened using Allen bolts of size 6.

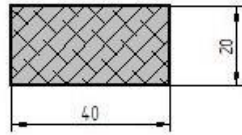

Side/front view of pulley fixed at top support bar

Figure Number.7.6: Side/front view of top support bars

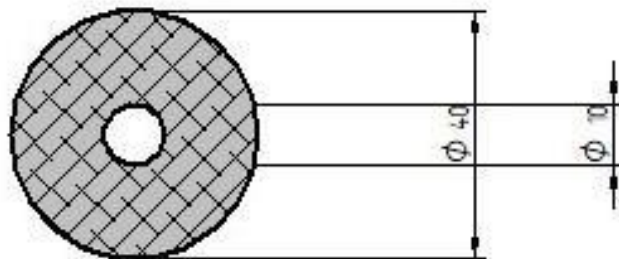

Top View of Pulley fixed at top support bar

Figure Number.7.7: Top view of pulley

2nd pulley (fixed to smaller motor 85 model)

Diameter: 25 mm

Number of teeth: 44

Material: Aluminium fibre

Type: Toothed lip runner

Fixed to a centre axle which acts as a transmission for both wheels.

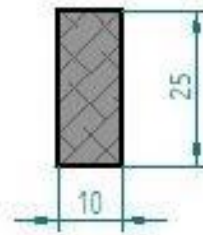

Side view of pulley for small motor

Figure Number.7.8: Side view of pulley for small motor

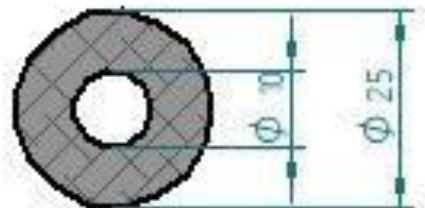

Pulleys for small motor

Figure Number.7.9: Top View of pulley for small motor

7.1.5. Support bars Length:

240 mm

Width: 440 mm

Quantity: 2

Place of Assembly: one on topmost connecting 2nd extrusion rods.

Other in the hinged part connecting 2nd extrusion and 1st extrusion rods.

Tightened using Allen bolts of size 6.

Department of Mechanical Engineering, PES University

Other components attached: Pulley Assembly

Volume of component: $1.08 \times 10^{-4} \text{ m}^3$

Weight of component: 2.86 kgs

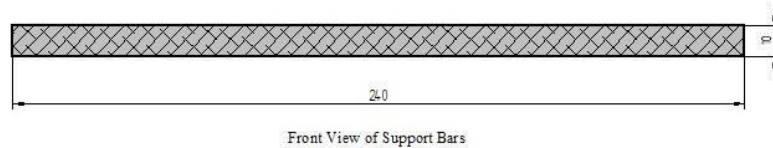

Figure Number.7.10: Front view of support bars

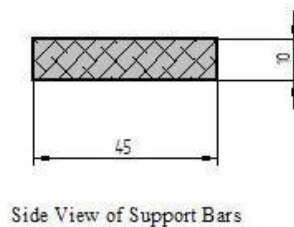

Figure Number.7.11: Side view of support bars

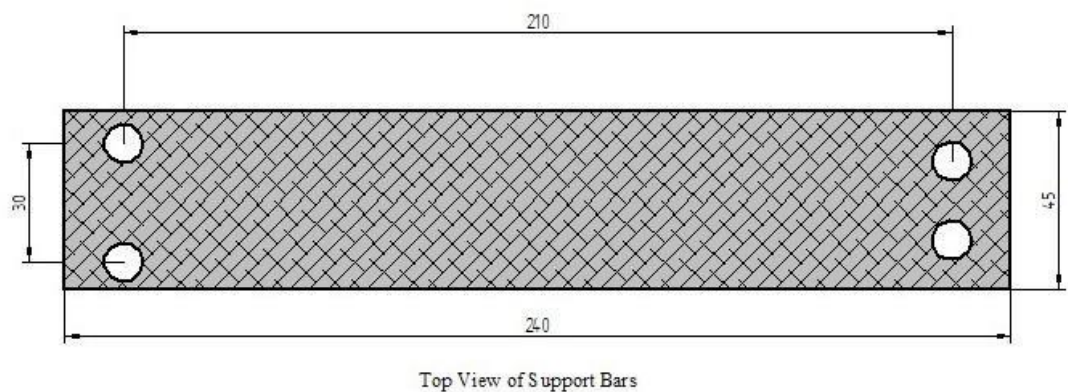

Figure Number.7.12: Top view of Support bars

7.1.6. Ink Tank

Number of Chambers: 6

Cyan and Magenta have 2 chambers as ink needed for any given print for these constituents is more.

Black and Yellow are single chambers.

Place of Assembly: on top of head for easier flow of ink supported through gravity and negative pressure.

Protected by steel box due to UV ink used and could be cured by UV rays of the sun.
Hence for longer storage this is protected.

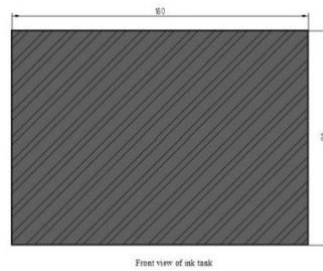

Figure Number.7.13: Front view of ink tank

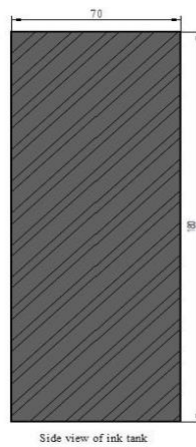

Figure Number.7.14: Side view of ink tank

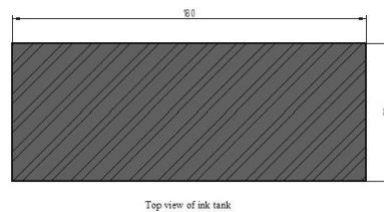

Figure Number.7.15: Top view of ink tank

7.1.7. Tubing Diameter:

3 mm

Material: Plastic

A 2 flow to single flow joint is used to combine the 2 outlets of cyan and magenta into a single outlet as head supports only 4 inlets.

Place of Assembly: Inside head box assembly in between the decoder and head and from ink tank.

7.1.8. Ink Type: UV

ink

Colours: Cyan, Magenta, Yellow, Black

7.1.9. Base

Material: Aerospace grade aluminium

Place of assembly: Down of main assembly, acts as mounting for everything.

Wheels and axle mounted down on base.

Rectangular cross section cut for conveyor belt passage.

Length: 520mm

Width: 370 mm

Thickness: 10 mm

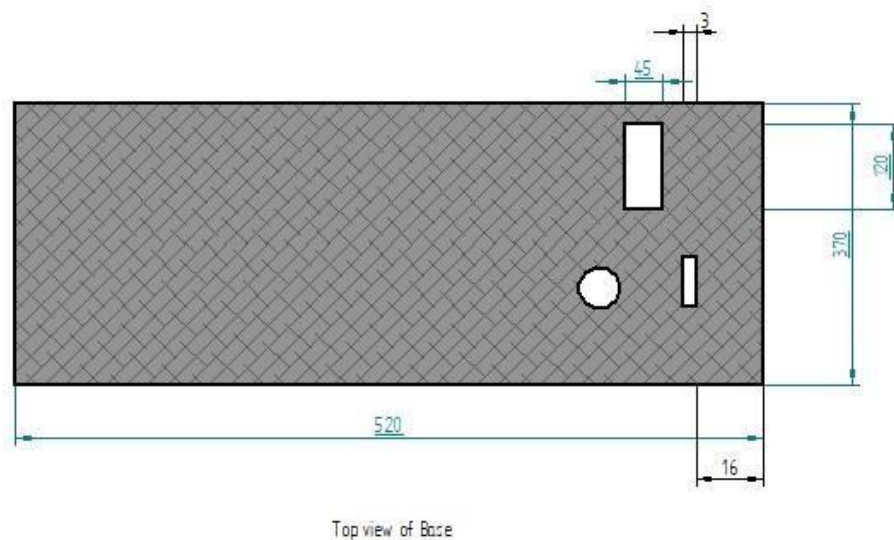

Figure Number.7.16: Top view of Base

7.1.10. Robo wheels Material:

Plastic

Type: Hub Centred wheels

Place of assembly: down of base

Quantity:4

Tightened using Allen bolts of size 6.

Type: Hub Centric

Department of Mechanical Engineering, PES University

Outer Diameter: 140 mm

Inner diameter: 120 mm

Width: 38 mm

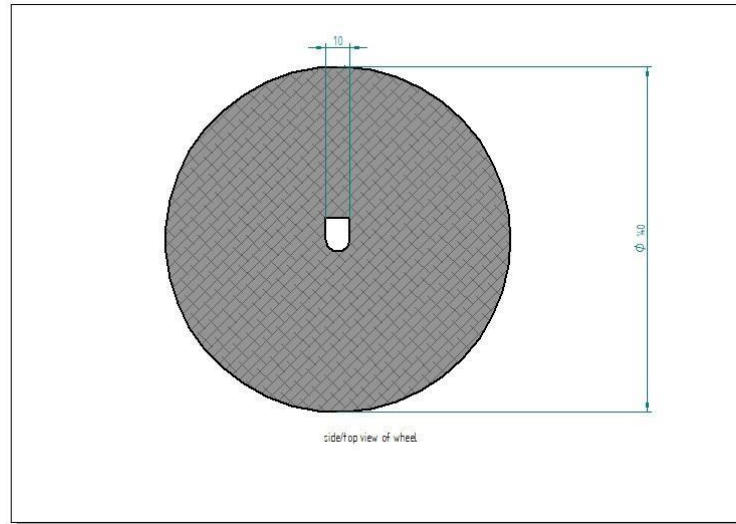

Figure Number.7.17: Front view of wheel

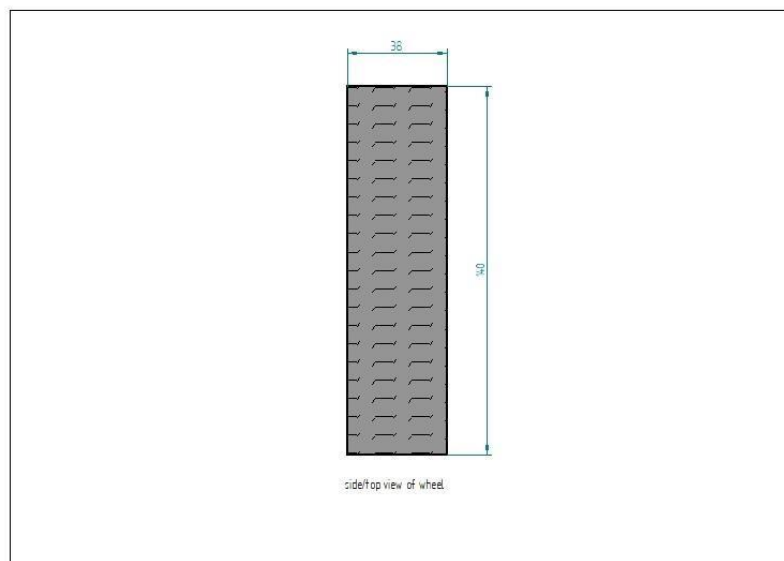
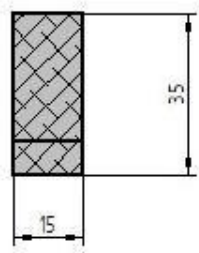

Figure Number.7.18: Side and top view of wheel

7.1.11. Support Structure for Pulley (one sided)

Material: Aluminium grade

Quantity Used: 2



Front view of support structure for pulley (single side)

Figure Number.7.19: Front view of support structure

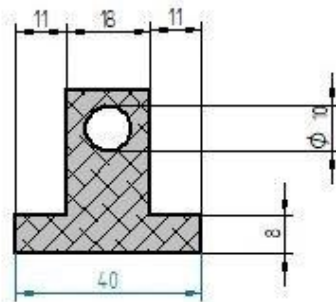

Side view of support structure for pulley (single side)

Figure Number.7.20: Side view of support structure for pulley

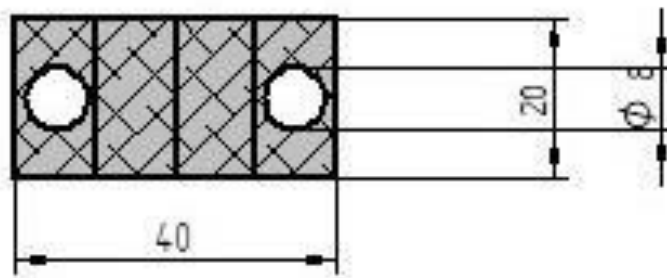

Top view of support structure for pulley (single side)

Figure Number.7.21: Top view of support structure

7.1.12. Rubber Stopper Material:

Rubber

Quantity: 2

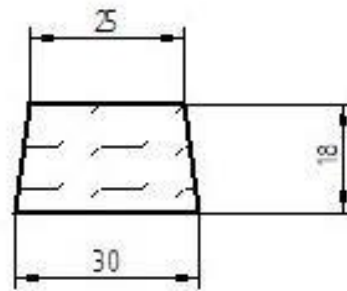

Front/side view of rubber stopper

Figure Number.7.22: Front/side view of rubber stopper



Top view of Rubber Stopper

Figure Number.7.23: Top view of rubber stopper

7.1.13. Conveyor casing

Material: Plastic

Spans for protecting cable which will connect head when moving.

Length: 1540 mm

Width: 40 mm

Thickness: 20 mm

7.1.14. Support bars (near hinges)

Material: Aerospace Grade aluminium

Other components: Pulley assembly

Mass of component: 0.292

Weight of component: 2.86 kgs

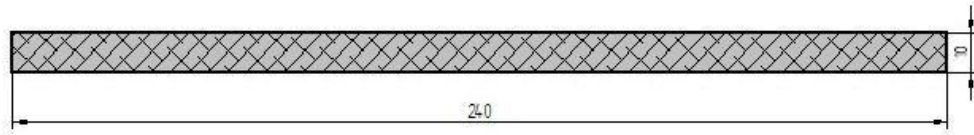

Front view of support bar (normal supports)

Figure Number.7.24: Front view of support bar

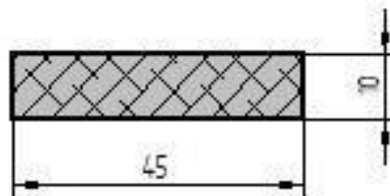

Side view of Support bars (normal supports)

Figure Number.7.25: Side view of support bars

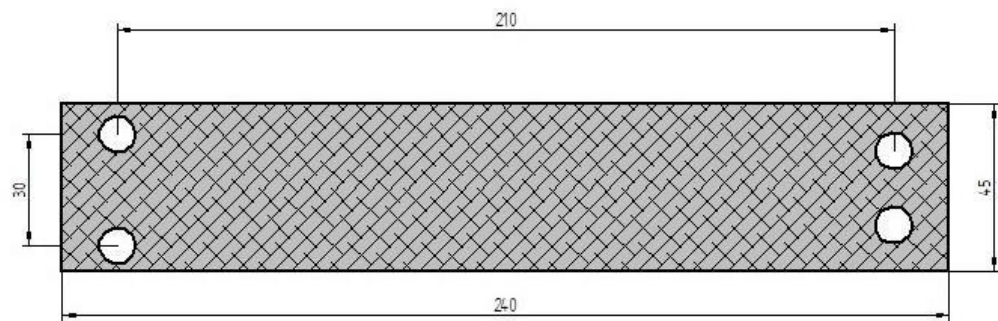

Top View of Support Bars

Figure Number.7.26: Top view of support bars

7.1.15. Folding Supports

Material: Normal Aluminium

Quantity: 2

Other components attached: Extrusion rods

Department of Mechanical Engineering, PES University

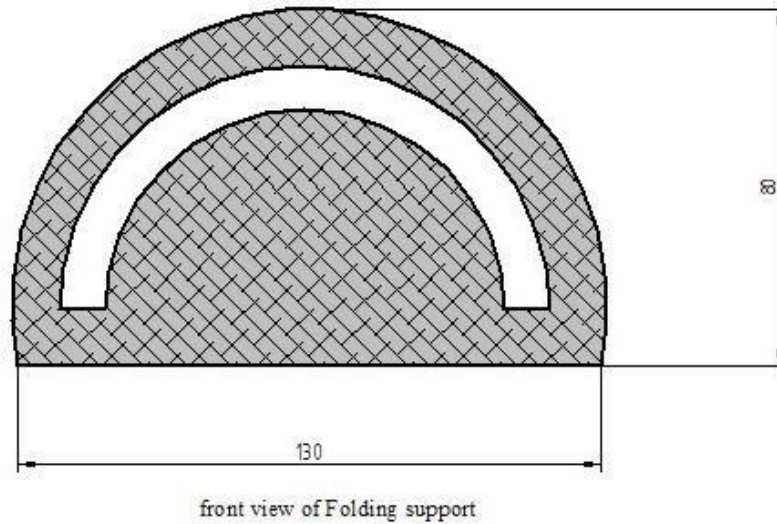

Figure Number.7.27: Front view of folding support

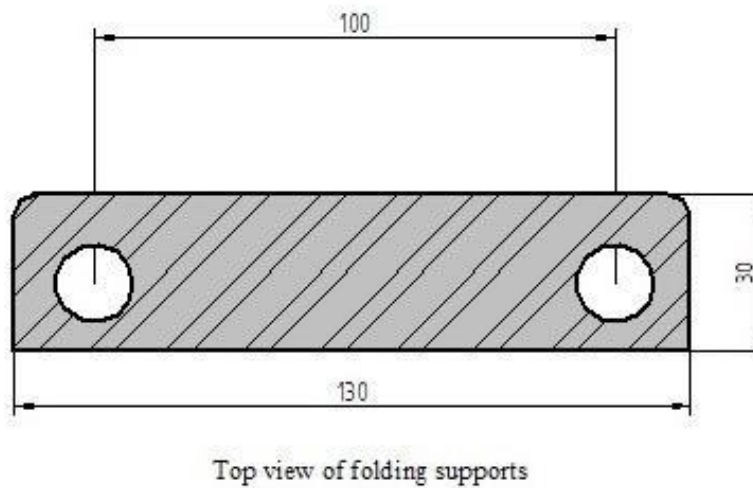

Figure Number.7.28: Top view of folding support

7.1.16. Tension belt (white Colour)

Assumptions made for this component:

Considering total mass as 220 grams approx.

Length of belt overall: 4880 mm

First end connection: Damper plate top

2nd end connection: Damper plate bottom

Width: 15 mm

Tension calculations in between 2 ends: $T = 4ml^2f^2$

Where m is belt mass/metre

L is Belt span in metres

$220/4.88 = 0.045$ kg/m

Belt frequency is assumed to be: 100 Hence

after substitution: $T = 428.65$ N

Span of belt: $\sqrt{\frac{CD^2}{4} - (D - d)^2}$

7.1.17. Tension belt for axle and wheels

Length: 960 mm

Width: 15 mm

Tension in belt assuming 100 hz as frequency and the mass of belt as 44 grams

$T = 1658.88$ N

Material used: fibre

7.1.18. Pulley for big motor

Diameter: 30 mm

Quantity: 2

Material: Aluminium

Type: Non toothed inner lip runner

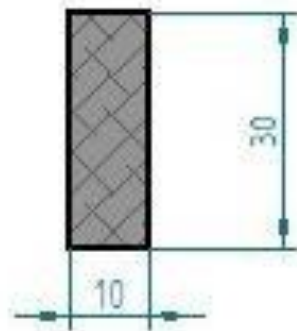

Side view of Bigger pulley for motor

Figure Number.7.29: Side view of bigger pulley

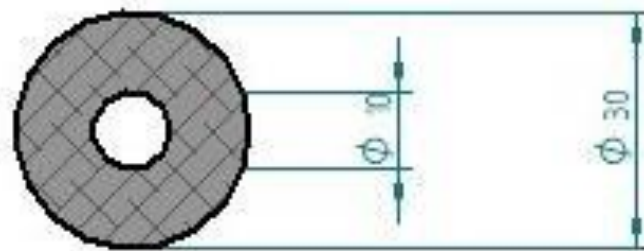

Bigger Pulley for Motor

Figure Number.7.30: Top view of bigger pulley

7.1.19. Ball bearing for axle Outer

diameter: 55 mm

Inner diameter: 35 mm

Department of Mechanical Engineering, PES University

Width: 25 mm

Material: Steel

Quantity: 4

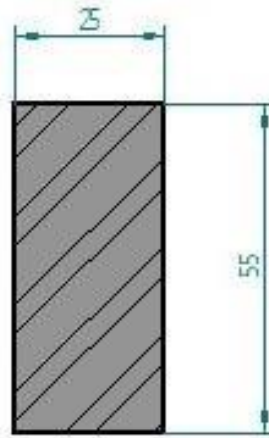

front/top view of ball bearing

Figure Number.7.31: Front/top view of ball bearing

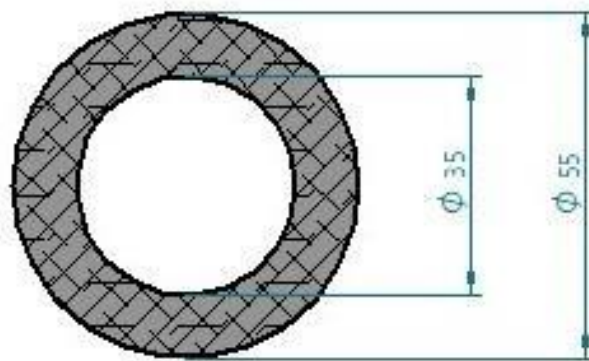

side view of ball bearing

Figure Number.7.32: Side view of ball bearing

7.1.20. Axle pulley Outer

Diameter: 70 mm

Type: Toothed lip runner

Inner diameter: 35 mm

Width: 20 mm

Material: Aluminium

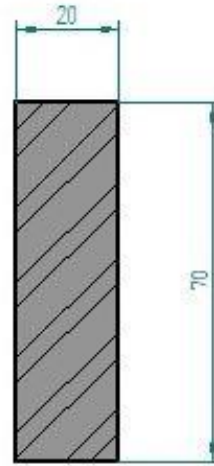

Side view of axle pulley

Figure Number.7.33: Side view of axle pulley

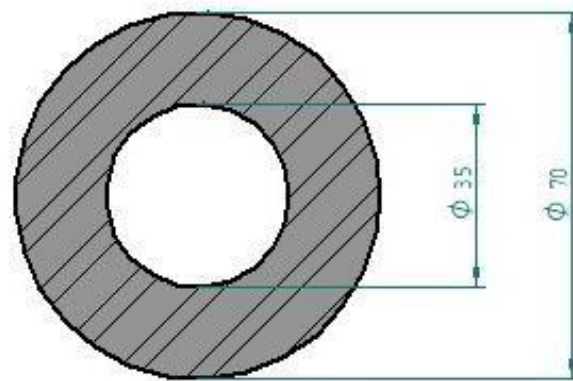

Top view of axle pulley

Figure Number.7.34: Top view of axle pulley

7.1.21. Axle support Length:

370 mm

Width: 100 mm

Department of Mechanical Engineering, PES University

Quantity: 4

Thickness: 10 mm

Material: Aerospace grade aluminium

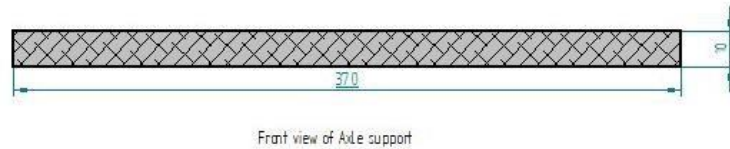

Figure Number.7.35: Front view of axle support

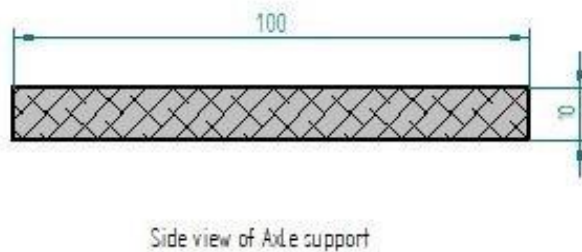

Figure Number.7.36: Side view of Axle support

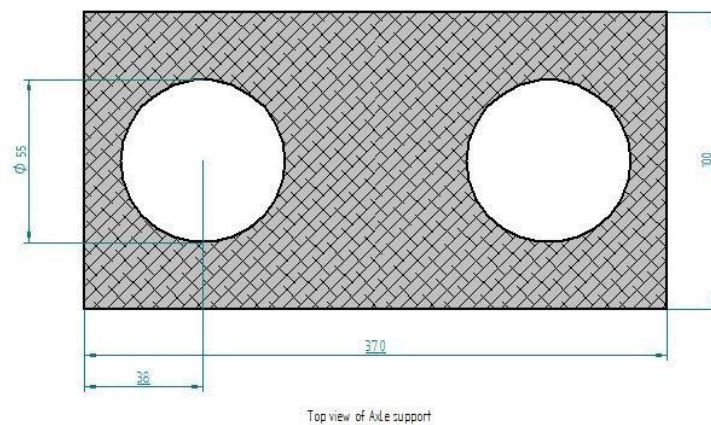

Figure Number.7.37: Top view of axle support

7.1.22. Axle

Length: 405 mm (bearing to bearing)

Length: 455 mm (Hub to Hub)

Diameter: 35 mm

Quantity: 2

Material: Aluminium

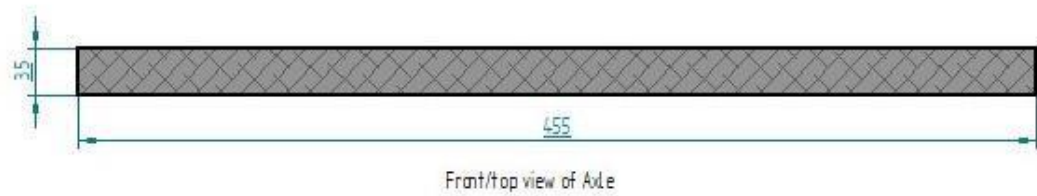

Figure Number.7.38: Front/top view of axle

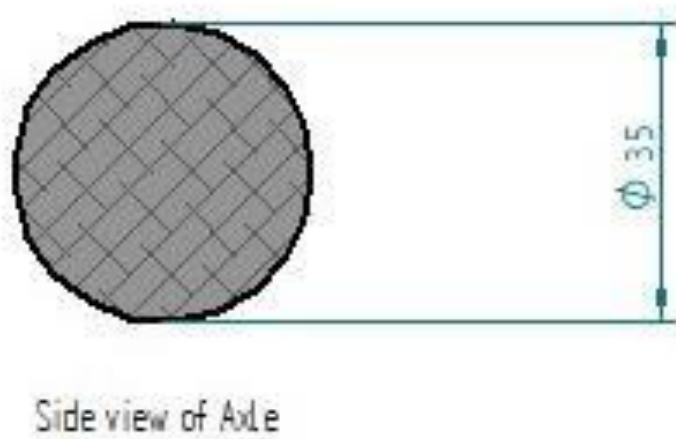
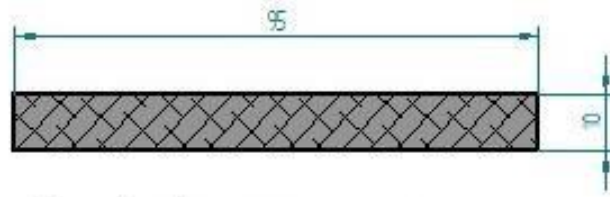

Figure Number.7.39: Side view of axle

7.1.23. Support for the stepper motor

Material: Aluminium

Other components attached: Stepper motor model 85



Front view for stepper motor support

Figure Number.7.40: Front view for stepper motor support

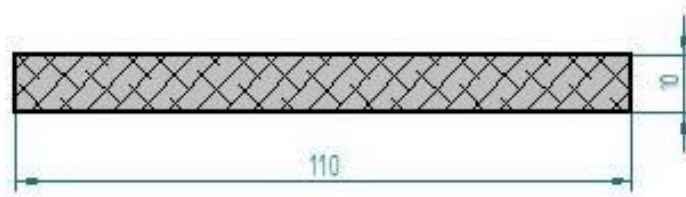

Side view of Support for stepper motor

Figure Number.7.41: Side view of support for stepper motor

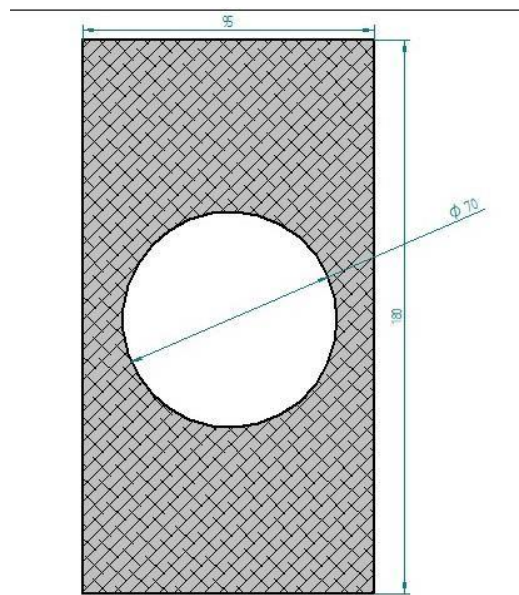

Top view of Support for stepper motor

Figure Number.7.42: Top view of support for stepper motor

7.1.24. Pulley for head travel Type:

Toothed lip runner

Material: Aluminium

Width: 16 mm

Outer diameter: 65 mm

Inner diameter: 15 mm

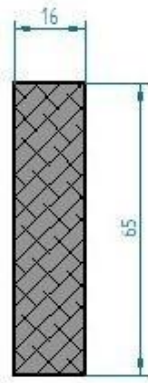

Side/front of pulley for head travel

Figure Number.7.43: Side/front of pulley for head travel

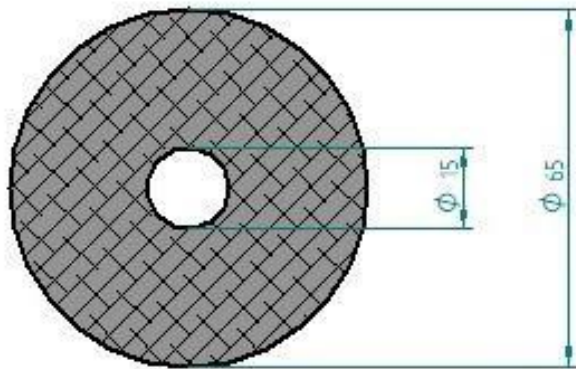

Top view of Pulley head travel

Figure Number.7.44: Top view of pulley head travel

7.1.25. Head plate Width:

140 mm

Length: 350 mm

Department of Mechanical Engineering, PES University

Thickness: 10 mm

Material: Aerospace Grade aluminium

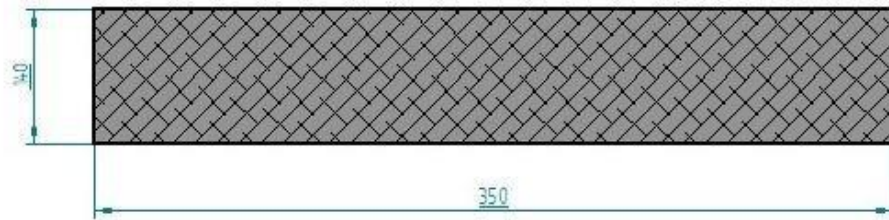

Front view of head plate

Figure Number.7.45: Front view of head plate

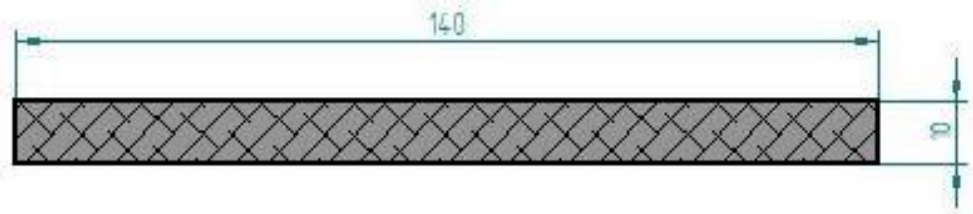

Side view of head plate

Figure Number.7.46: Side view of head plate

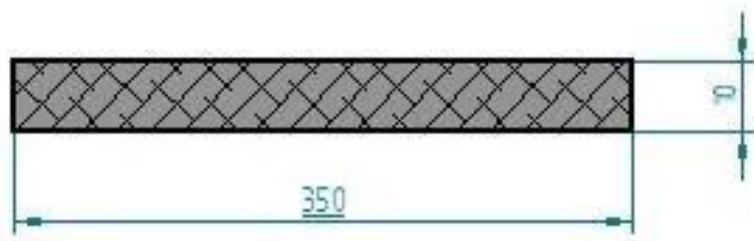

Front view of head plate

Figure Number.7.47: Front view of head plate

7.1.26. Roller Mount plates

Length: 140 mm

Width: 20 mm

Thickness: 15 mm

Material: Aerospace Grade aluminium

Quantity: 2

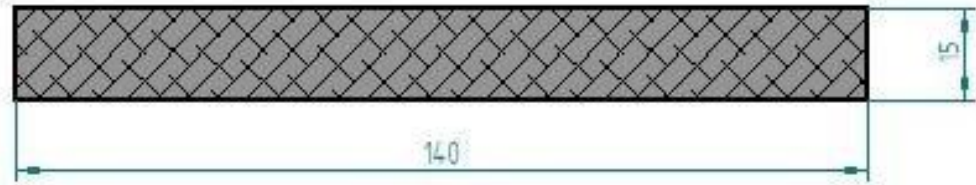

Front view of roller mount plates

Figure Number.7.48: Front view of roller mounts

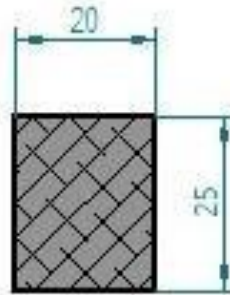

Side view for roller mount plates

Figure Number.7.49: Side view for roller mount plates

7.1.27. Tension belt for Head (Black)

Length: 30 mm belt

Material: Rubber Compound

Department of Mechanical Engineering, PES University

Width: 15 mm

Mass of equipment: 25 grams

Frequency: 100 Hz (assumed)

Manufacturer: 3M

Tension: $4ml^2f^2 = 30N$

7.1.28. Rollers

Type: Rubber compound

Quantity: 6

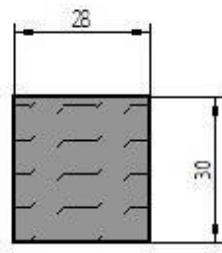

Front/side of rollers

Figure Number.7.50: Front/side of rollers

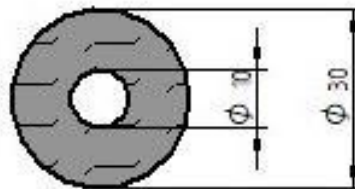

Top view of roller

Figure Number.7.51: Top view of roller

CHAPTER**8****NUMERICAL SCHEME**

Maximum printable height: 1350 mm from head start + 508 mm picture height = 1858 mm

Maximum printable width: Unlimited if power supply is available and space. Would depend on aspect ratio as well and type of image chosen.

Maximum Printing resolution: 5760 by 2880

Ordinary Printing Resolution: 1440 by 720

Pixel Density: 360 dpi

Directions: Bidirectional head printing for faster operation and low printing time.

Speed settings: Slow/normal/fast

Power requirements: AC 110V (90- 132V)

AC 220V (180 – 264V)

Frequency: 47 – 63Hz

Tension calculations in between 2 ends: $T = 4ml^2f^2$

Where m is belt mass/metre

L is Belt span in metres for the white belt

$220/4.88 = 0.045$ kg/m

Belt frequency is assumed to be: 100

Hence after substitution: $T = 428.65N$

Tension in belt assuming 100 hz as frequency and the mass of belt as 44 grams

$T = 1658.88$ N

CHAPTER

9

FLOW DIAGRAM

9.1. Command Diagram

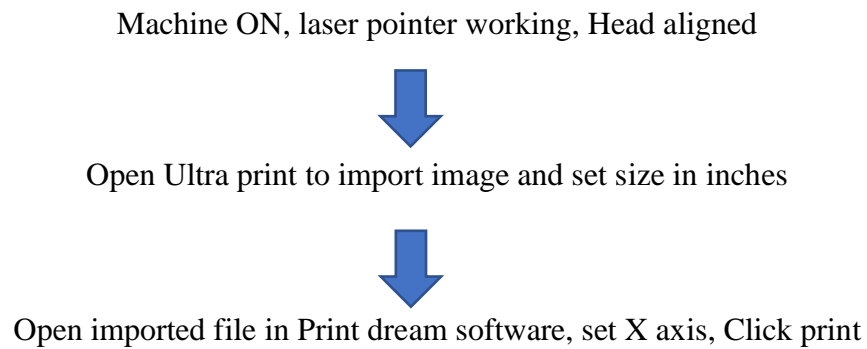

9.2. Signal Flow Diagram

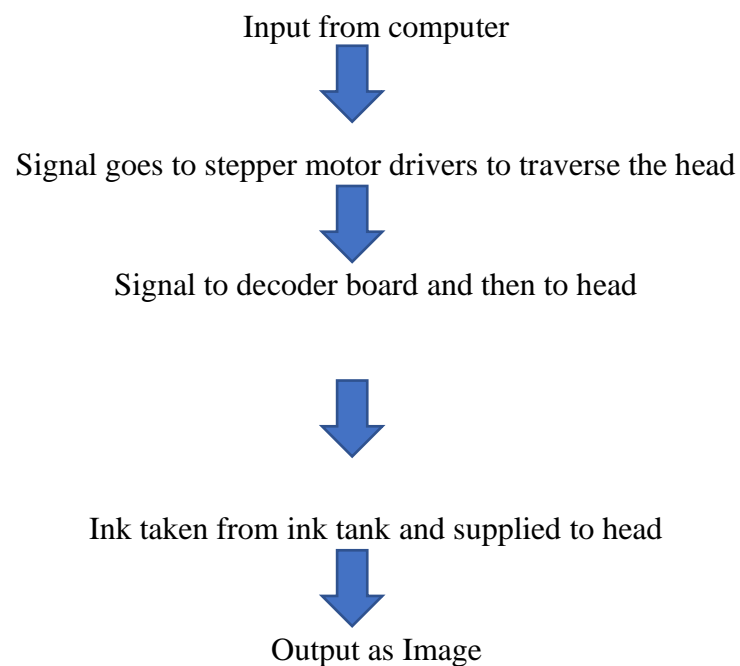

CHAPTER

10

EXPERIMENTAL SETUP AND CALIBRATION

Head and Decoder Assembly: 4 slots in the decoder board have 14 pin connections, and 4 slots have 16 pin connections. The 14-pin connection are the print head connection which go directly into the head as shown here,



Figure Number.10.1: Head side

The decoder boards 16 pin connectors are connected to the motherboard. The 16 pin slots are the topmost slots in the decoder board. Decoder board shown in Fig.3.



Figure Number.10.2: Decoder board

All these cables were connected to test board working. If working the lights glow amber in the board.

These connections were made using flat same sided ribbon cables as shown



CHAPTER

Figure Number. 10.3: Flat cables

4 nozzle profile of the head with CMYK colour input. Nozzles are plugged with the plastic tubing and supply is given from the ink tank. Nozzles showing here in Fig.5.



Figure Number.10.4: Head nozzles

Motherboard connections from SMPS to the monitor using the VGA cable and the USB 2.0 for mouse are shown here in

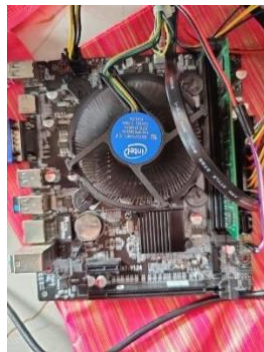

Figure Number.10.5: Fan

Stepper motor connections from supply to output. Down cable for input and up for output. shown here



Figure Number.10.6: Stepper Driver

CHAPTER 11

INVESTIGATIONS AND REDUCTIONS

During experimentation of the working of the model, it was found that the head was flowing back ink into the tubing due to which there was not enough pressure for ink to come out through the head. This is mainly since UV ink hardens when exposed to air for long period of time, and also when its stationary. The properties of ink change and this flowed through the head nozzle and blocked the nozzle due to which it was throwing the ink back.

Reduction and solution: We need to open the pressure caps on the ink tank when printing is in operation. But this resulted in spillage and hence the ink tank was replaced. The old ink tank is shown here in



Figure Number.11.1: Ink tank.

The new ink tank has pressure caps along with filling caps and is shown here in



Figure Number.11.2: Ink tank

The blockage in the yellow and magenta nozzle during testing is shown here in



Figure Number. 11.3: Nozzle

The print speed when set to normal and unit directional will print a 20 inch by 20-inch photo with basic resolution in 18 minutes and 23 seconds. This calculated time is the time from start of head movement from the home position to the return of head to home position. The picture which was printed is shown in.

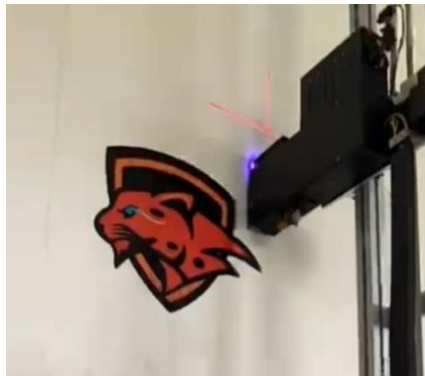

Figure Number.11.4: Image

Printing files should be saved in prn format and any other format should be first converted to prn and then print command can be given. Ultra-print is the software used to scale the images and set dimensions. Print dream is the software which is used for head positioning and printing command. This contains all controls of the machine-like movement and head status checks.

The highest resolution of image on A4 size sheet paper is 595 by 842 pixels which translates to 72DPI. This is given by high quality printers such as Epson Ecotank L6580. Comparing this to the current machine, it can produce 360 dpi according to the aspect ratio set. The best quality would be 5760 by 2880 provided by this software.

The noise levels of the machine were tested in a controlled environment (closed windows/doors, no fans, no physical movement by operator) by using iOS software which

is readily available in Apple devices. The standby noise levels were recorded and the average after 10 tests was 14.6dB. Same was tested for working state of printing an image and noise levels for an average of 10 tests was 48.7 db.

Ink wastage according to the head specs is 10-15 ml per sqm. A full tank of ink can hold 360ml of combination colours and can be refilled 3 times comfortably using the cartridges available.

CHAPTER 12

BILL OF MATERIALS

| Material | Quantity | Total Cost in Rupees |
|--------------------------------------|-------------------|-----------------------------|
| Aluminium Rods | 2(split into 4) | 7100 |
| Fabrication and Gas welding for Rods | 4 | 800 |
| Support Beams | 4 | 2400 |
| Base | 1 | 8800 |
| Slotting for Base | 1 | 800 |
| Robo Wheels | 5 | 1000 |
| Pulleys | 4(1 small, 3 big) | 900 |
| Tension Belts | 3 | 700 |
| Wooden Box | 1 | 8800 |
| Washer | 8 | 80 |
| Allen Bolts | 30 | 330 |
| Axle Beam (steel rod) | 2 | 300 |
| Bearing for wheels | 4 | 1000 |
| Bearing press tool(rented) | 1 | 200 |
| Hinges | 2 | 400 |

| | | |
|--------------------------------|------|-------|
| Ink Tank 6 chamber | 1 | 600 |
| Ink Tank tubing | 1 | 50 |
| Ink Tank Casing | 1 | 450 |
| Ink | 8(2) | 11200 |
| Conveyor Casing | 1 | 300 |
| Support structure material | 1 | 400 |
| Support fabrication | 1 | 700 |
| Rubber Stops | 3 | 30 |
| Folding supports | 2 | 500 |
| Stepper motor support material | 1 | 300 |
| Fabrication of support | 1 | 400 |
| 3M Tension belt | 1 | 200 |
| Head Casing | 1 | 900 |
| Roller Mount plate | 1 | 1200 |
| Rollers | 6 | 100 |
| Flat cables | 8 | 500 |
| Decoder board | 1 | 9840 |

| | | |
|---------------------------------------|---|-------|
| Print head | 1 | 43100 |
| Shipping cost | 1 | 2430 |
| Customs Clearing | 1 | 10200 |
| Stepper motor large 110 | 1 | 5500 |
| Shipping | 1 | 660 |
| Stepper motor model 85 | 1 | 4600 |
| Shipping | 1 | 520 |
| Stepper motor model 35 | 1 | 2690 |
| Shipping | 1 | 320 |
| Cat6 cable | 1 | 360 |
| Ethernet cable | 2 | 250 |
| Printing cable to USB | 1 | 300 |
| Stepper driver cable | 4 | 500 |
| Stepper motor driver model HBS86H | 1 | 8400 |
| Stepper motor 2H micro step driver | 1 | 3550 |
| Driver Cables pinned | 8 | 1200 |

| | | |
|---------------------|---|-------|
| UV Curing light | 1 | 4500 |
| Motherboard (used) | 1 | 11000 |
| Intel i3 CPU (used) | 1 | 6650 |

| | | |
|----------------------------|---|-------|
| Fan for CPU | 1 | 800 |
| Shipping for CPU and board | 1 | 350 |
| Adhesive | 1 | 200 |
| SMPS module | 1 | 650 |
| Printer motherboard | 1 | 12660 |
| Head mounting plate | 1 | 400 |
| Rubber gasket for head | 1 | 100 |
| Head Ink Suction | 1 | 2000 |
| Shipping | 1 | 250 |
| Monitor | 1 | 8800 |
| Hard disk | 1 | 1550 |
| SSD | 1 | 2500 |
| Connecting channeler | 1 | 8840 |
| Wiring for motherboard | 1 | 380 |

| | | |
|-----------------------|----|---------------|
| Wire for power supply | 1 | 150 |
| Buttons | 1 | 100 |
| Wooden box carpentry | 1 | 800 |
| Mouse and keyboard | 1 | 330 |
| Snowfan | 1 | 880 |
| Fastening Nuts | 15 | 300 |
| Stepper Power control | 1 | 2250 |
| VGA cable | 1 | 400 |
| Power adapter | 1 | 700 |
| Board diagnosis | 1 | 5600 |
| Cable arranger | 1 | 250 |
| Miscellaneous | 1 | 2600 |
| GRAND TOTAL | | 221850 |

GRAND TOTAL IN WORDS: TWO LAKH TWENTY-ONE THOUSAND EIGHT HUNDRED AND FIFTY ONLY

CHAPTER 13

RESULTS AND DISCUSSIONS

We have designed and fabricated the model keeping in mind the working conditions and the type of service which it would be required for. We have incorporated as much controls as possible for the ease-of-use application and made corrections for the investigations we encountered. The cost of ink cartridges as of now is 5500 Rs for set of all colours. These cartridges are 400 ml and can refill ink tank thrice before exhaustion. This is now delivering images of high quality on the wall. Quality of print was tested using EPSON photo print software, which is available only for home and commercial printing heads and is only compatible with the same. The maximum resolution which is producible with the print head is 2160p by 1080p which is available only for A3 sheet paper. The maximum resolution available for us mimicking the A3 sheet which is 297mm by 420 mm is 2860p by 1080p which is greater than the regular commercial printing head can produce. The size of the printer rails in the software are limited according to the size of the paper which the tray can accommodate whereas here there are no limitations. The quality of print related to DPI (dots per inch) was calculated comparing to a A3 size paper, and the best quality producible is 300 DPI. Same comparison done with the machine, and it could produce 330 DPI, which is greater than the commercial printing device. Hence the machine can produce small images with near to similar print quality as a normal printer would be able to do and would also produce large images with commendable quality and finishes.

CHAPTER 14

CONCLUSIONS AND SCOPE FOR FUTURE WORK

We have successfully fabricated the machine to print on walls with limited amount of time. The future of this can be a business model which delivers prints in certain areas of a building which is stationary for the rest of its life. The main scope is for cost cutting in the printing sector. The amount of ink cost required is calculated using rigorous testing and many trials should be taken on different quality of paints. The wall surface also matters during this, and tests should be conducted using different materials with different absorption rate. We have calculated using a few trials and the projection for the same lead us to deciding the cost per square inch. The cost turns out to be 13 Rs per square inch including the run time from start to switch off. And a set of cartridges can print around 30 prints. The area covered can be around 3200 sq. ft of wall. These figures are just projected using the amount of ink used during our testing process. There are a lot of errors like wall material, viscosity variation using temperature, and hence the cost is just a subjected approximation. A high level of engineering analysis is required to arrive at an exact cost with tolerance.

CHAPTER 15

REFERENCES

1. Shenzhen Liyu Technologies Pvt Ltd, Shenzhen, China.
2. Aditya Laminates.
3. NCMPC- 2019 Proceedings
4. ACP Sheets for Building Exteriors by ARECA